

# 内徑牙刀 Micro Internal Threading

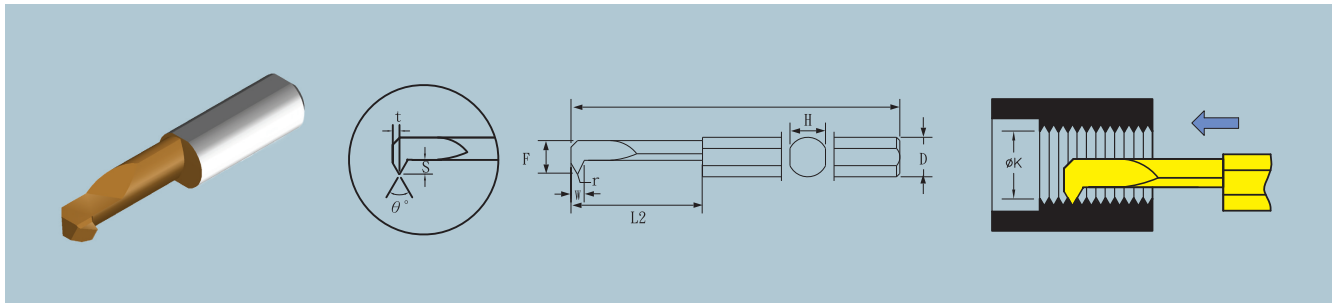

型號 EDP NO.	$\theta^\circ$	ØK	F	t	W	L2	L	r	S	ØD	Pich	TPI	在庫 stock	適用套筒 Applicable Sleeve
51.4015-60004	60	4.5	3.8	0.7	1.5	15	45	0.04	1.3	4	p0.5~p1.25	48~24	●	SP.250-04**
51.6020-60005	60	6.0	5.0	0.8	1.8	20	55	0.05	1.6	6	p0.75~p1.5	28~16	●	SP.250-06**
51.8030-60007	60	8.0	7.0	1.2	2.5	30	75	0.07	2.0	8	p1.0~p2.0	20~12	●	SP.250-08**
51.4015-55005	55	4.5	3.8	0.7	1.5	15	45	0.05	1.3	4		32~24		SP.250-04**
51.6020-5501	55	6.0	5.0	0.8	1.8	20	55	0.1	1.6	6		28~20		SP.250-06**
51.8030-5501	55	8.0	7.0	1.2	2.5	30	75	0.1	2.0	8		28~14		SP.250-08**

# 内徑牙刀 Micro Internal Threading

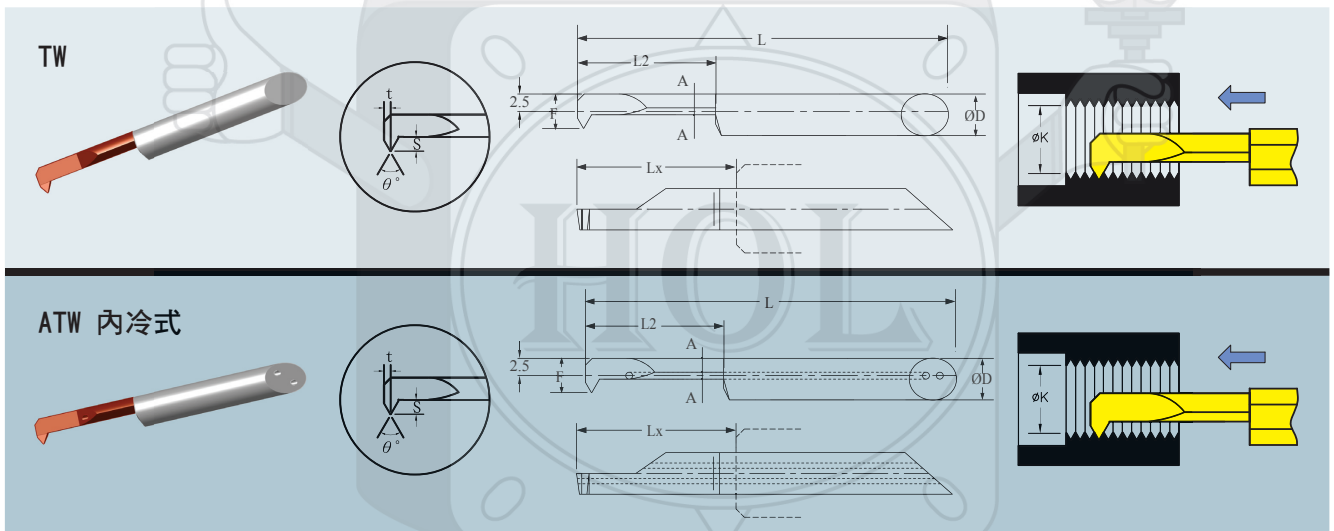

型號 EDP NO.	内冷式 型號 EDP NO.	$\theta^\circ$	ØK	F	t	W	L2	Lx	r	S	ØD	Pich	TPI	在庫 stock	適用套筒 Applicable Sleeve
TW 51.4015-60004	ATW 51.4015-60004	60	4.5	3.8	0.7	1.5	15	17	0.04	1.3	4	p0.5~p1.25	48~24		SP.250-04**
TW 51.5015-60005	ATW 51.5015-60005	60	5.5	4.8	0.7	1.5	15	17	0.05	1.3	5	p0.75~p1.25	48~24		SP.250-05**
TW 51.6020-60005	ATW 51.6020-60005	60	7.0	5.8	0.8	1.7	20	23	0.05	1.6	6	p0.75~p1.5	28~16		SP.250-06**
TW 51.7025-60005	ATW 51.7025-60005	60	8.0	6.8	0.8	1.7	25	28	0.05	1.8	7	p0.75~p1.5	28~16		SP.250-07**
TW 51.8030-60007	ATW 51.8030-60007	60	9.0	7.8	1.2	2.5	30	33	0.07	2.0	8	p1.0~p2.0	20~12		SP.250-08**
TW 51.4015-55005	ATW 51.4015-55005	55	4.5	3.8	0.7	1.5	15	17	0.05	1.3	4		32~24		SP.250-04**
TW 51.5015-55005	ATW 51.5015-55005	55	5.5	4.8	0.7	1.5	15	17	0.05	1.3	5		32~24		SP.250-05**
TW 51.6020-5501	ATW 51.6020-5501	55	7.0	5.8	0.8	1.7	20	23	0.1	1.6	6		28~20		SP.250-06**
TW 51.7025-5501	ATW 51.7025-5501	55	8.0	6.8	0.8	1.7	25	28	0.1	1.8	7		28~20		SP.250-07**
TW 51.8030-5501	ATW 51.8030-5501	55	9.0	7.8	1.2	2.5	30	33	0.1	2.0	8		28~14		SP.250-08**

無"●"標示者為訂製品。Without "●" marking means custom products.  
有"●"標示者為在庫品。With "●" marking means items in stock.